

Distribution and Regulation units

Datasheet
0861EN  04/2019

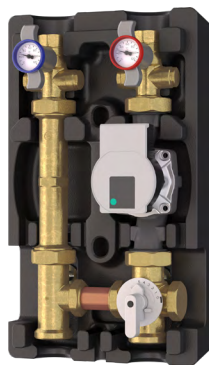

R586RY101



R586RY102

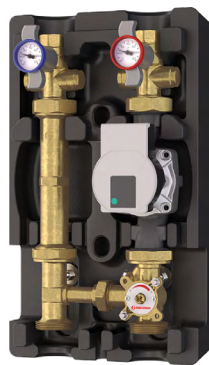

R586RY103

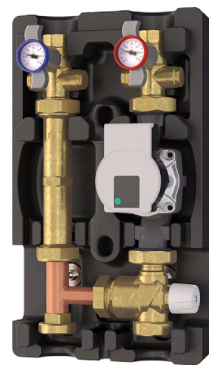

R586RY104



R586RY111



R586RY112



R586RY113

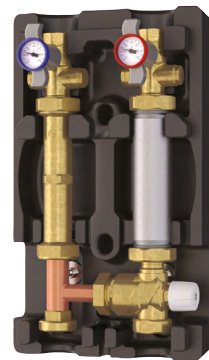

R586RY114



Unit with insulation and
actuator (optional)

R586R distribution units control heating and cooling for one zone of the system (R586RY104-114 for heating only). The R586RY101-102-103-104 versions include a low-energy consumption circulator complying with directive ErP 2009/125/CE, interception ball valves with integrated thermometer, check valve integrated in the return circuit and polypropylene foam rigid insulation (EPP).

The R586RY102-103-104-112-113-114 are equipped with a mixing valve; the actuator to control the mixing valve (when included) is sold separately.

The mixing valve actuators and the delivery temperature can be controlled with KLIMAbus thermoregulation products.



VIDEO

Frame the QR code with your smartphone or tablet to view the video tutorial.

➤ Versions and product codes

PRODUCT CODE	APPLICATION	DELIVERY/RETURN OUTPUTS REVERSIBILITY	CIRCULATOR	MIXING	
				MIXING VALVE	ACTUATOR (OPTIONAL)
R586RY101	Heating/Cooling	Yes	Wilo Para 25/7	-	
R586RY102	Heating/Cooling	Yes	Wilo Para 25/7	Ball mixing valve (R296)	K275Y002/011/013
R586RY103	Heating/Cooling	No	Wilo Para 25/7	Sector mixing valve (R297)	K275Y002/011/013
R586RY104	Heating only	Yes	Wilo Para 25/7	Thermostatic mixing valve	-
R586RY111	Heating/Cooling	Yes	Not included	-	
R586RY112	Heating/Cooling	Yes	Not included	Ball mixing valve (R296)	K275Y002/011/013
R586RY113	Heating/Cooling	No	Not included	Sector mixing valve (R297)	K275Y002/011/013
R586RY114	Heating only	Yes	Not included	Thermostatic mixing valve	-

Optional components

- **K275Y002:** actuator with integrated constant temperature regulator
- **K275Y011:** 3-point floating actuator controllable with KLIMAbus thermoregulation
- **K275Y013:** actuator with 0...10 V regulation controllable with KLIMAbus thermoregulation
- **R284Y021:** differential by-pass kit
- **R252Y001:** interception ball valve 1"F x nut 1 1/2"F, for installation upstream the distribution unit
- **KLIMAbus thermoregulation:** KLIMAbus thermoregulation components (regulation unit, thermostats, ambient probes, etc...)

Compatible circulators (for circulator-free units)

- Wilo Para - 180 mm centre distance
- Grundfos Alpha series - intersasse 180 mm

➤ General technical data

- Fluids: water, glycol-based solutions (max. 50 %)
- Temperature range: 5÷100 °C (5÷95 °C for R586RY104-114)
- Max. working pressure: 5 bar or 10 bar depending on versions
- Connections: system side: 1"F ISO 228
boiler side: 1 1/2"M ISO 228
outputs centre distance: 125 mm
- Circulator Wilo Para 25/6, 180 mm centre distance, complying with directive ErP 2009/125/CE (for versions with circulator)
- Galvanized steel spacer, 180 mm centre distance (for circulator-free versions)
- Interception ball valves with thermometers (scale 0÷120 °C) and connections for by-pass kit
- Check valve integrated on return circuit
- EPP insulation, density 35 kg/m³
- Wall-mount plate (screw anchors not included)

NOTE. Specific data referring to single R586R units are given in the following corresponding paragraph.

Materials

- Interception ball valves: CW617N brass body, PTFE sealings, plastic handle
- Spacer with check valve: CW617N brass body, POM check valve
- Polypropylene foam insulation (EPP)
- Gaskets: EPDM

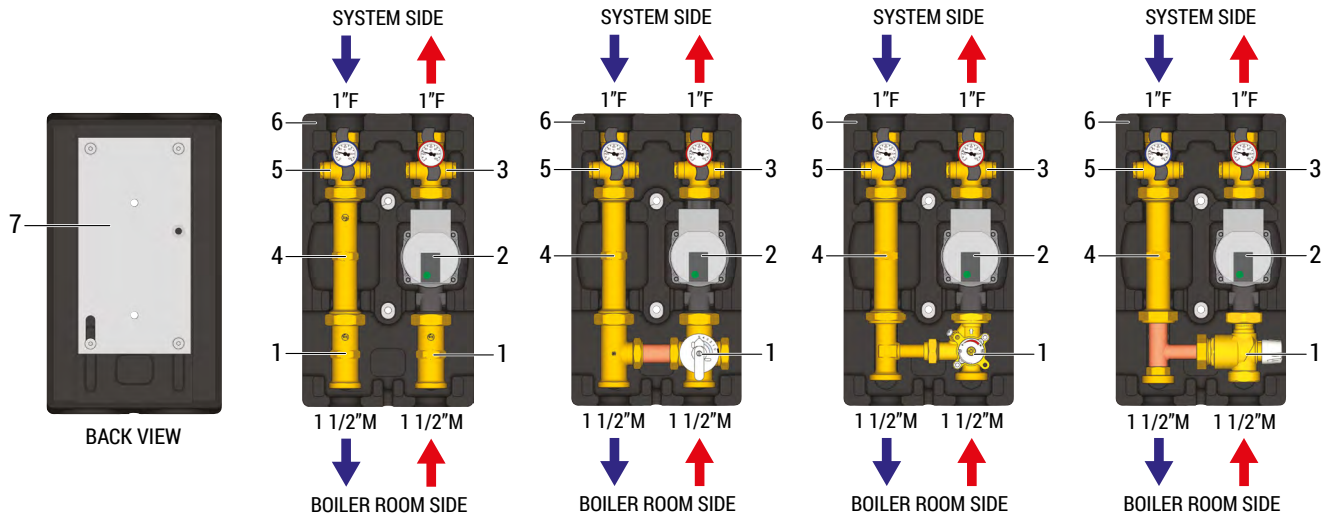

COMPONENT REFERENCE	R586RY101	R586RY111	R586RY102	R586RY112	R586RY103	R586RY113	R586RY104	R586RY114
1	Brass fitting		R296 mixing ball valve		R297 mixing sector valve		Mixing thermostatic valve	
2	Circulator	Galvanized steel spacer	Circulator	Galvanized steel spacer	Circulator	Galvanized steel spacer	Circulator	Galvanized steel spacer
3	Delivery ball valve, with thermometer and connections for by-pass kit		Delivery ball valve, with thermometer and connections for by-pass kit		Delivery ball valve, with thermometer and connections for by-pass kit		Delivery ball valve, with thermometer and connections for by-pass kit	
4	Spacer with integrated check valve		Spacer with integrated check valve		Spacer with integrated check valve		Spacer with integrated check valve	
5	Return ball valve, with thermometer and connections for by-pass kit		Return ball valve, with thermometer and connections for by-pass kit		Return ball valve, with thermometer and connections for by-pass kit		Return ball valve, with thermometer and connections for by-pass kit	
6	Insulation shell		Insulation shell		Insulation shell		Insulation shell	
7	Wall-mount plate		Wall-mount plate		Wall-mount plate		Wall-mount plate	

➤ Main features

Delivery/return outputs reversibility

R586RY101-111-102-112-104-114 units include reversible delivery and return outputs.
R586RY103-113 units instead are not reversible.

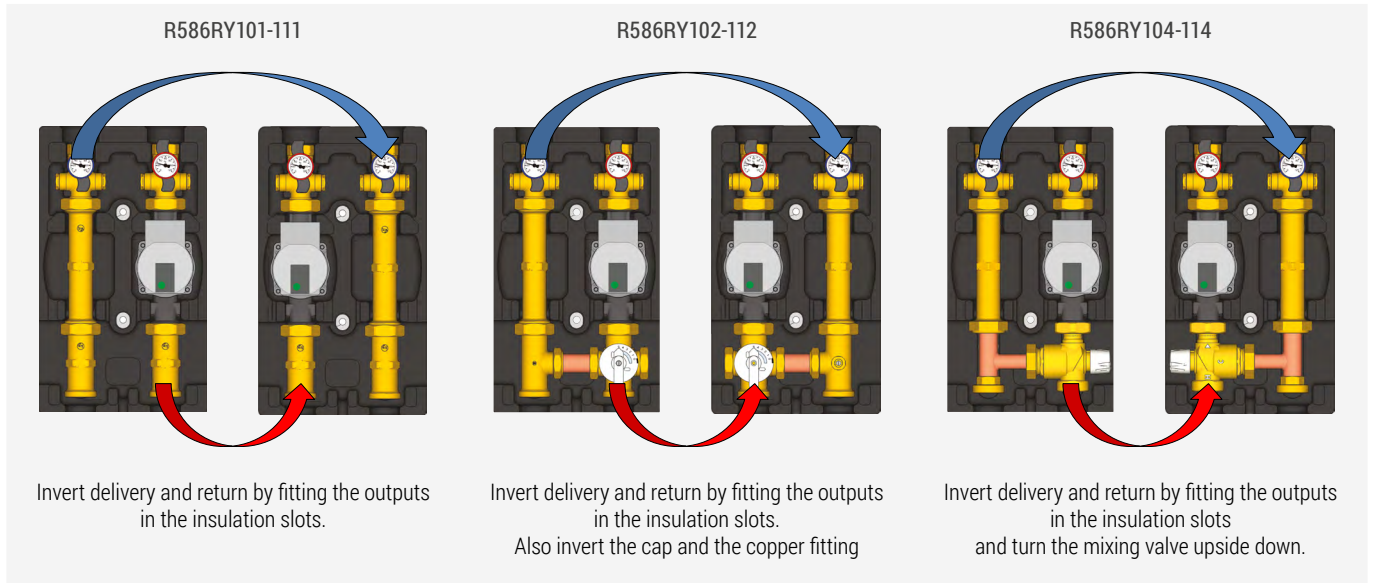

Check valve integrated on return output

All R586R units include a check valve inside the brass spacer top, on the return output.
The check valve can be disassembled by removing the Seeger ring used to fit it to the spacer.

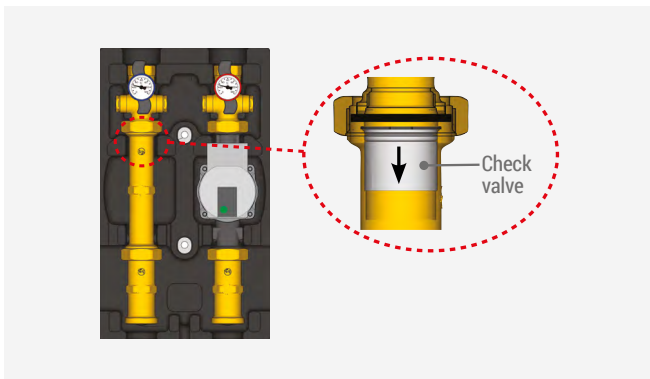

Installation of R252Y001 ball valves

R586R units can be intercepted by installing the R252Y001 ball valves upstream.
The ball valves can be opened and closed using a 5 mm Allen wrench.

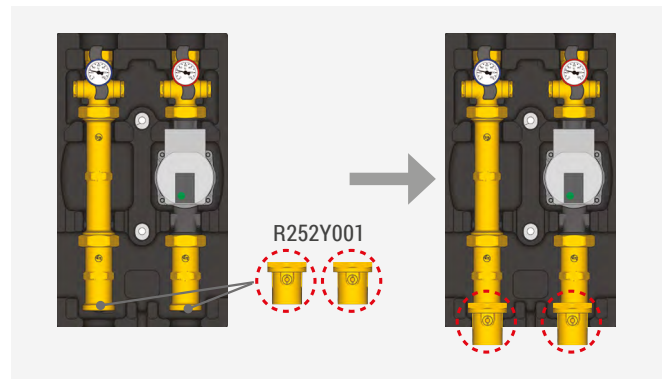

Installation of R284Y021 differential by-pass kit

The differential by-pass kit protects the circulator enabling water recirculation inside the R586R unit when the secondary system is off or completely closed.
The kit includes a brass spacer with integrated check valve calibrated at a fix value of 5 mH₂O, two nuts to be screwed on the interception valves and two PTFE gaskets.

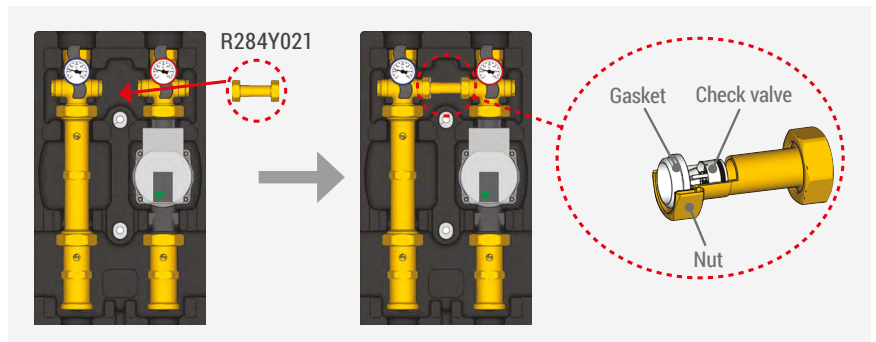



R586RY101 - R586RY111



➤ Operation

R586RY101 and R586RY111 distribution units without mixing valve are used in heating and cooling systems such as relaunching units for direct outputs of high/low temperature combined systems.

The units include interception valves with thermometer both on the delivery and return circuit and a check valve on the return spacer.

The two delivery and return outputs are reversible and a R284Y021 differential by-pass kit can be installed in between (see paragraph "Main characteristics").

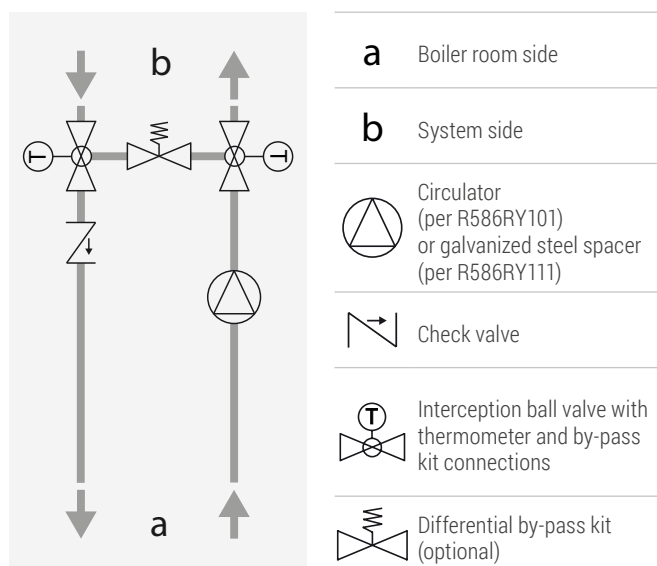

➤ Specific technical data

- Temperature range: 5÷100 °C
- Max. working pressure: 10 bar
- Connections: system side: 1" F ISO 228
boiler side: 1 1/2" M ISO 228
outputs centre distance: 125 mm
- Weight: 5,8 kg (with circulator); 4,0 kg (without circulator)

Materials

- Interception ball valves: CW617N brass body, PTFE sealings, plastic handle
- Spacer with check valve: CW617N brass body, POM check valve
- Polypropylene foam insulation (EPP)
- Gaskets: EPDM

Flow rate/power/hydraulic head diagram

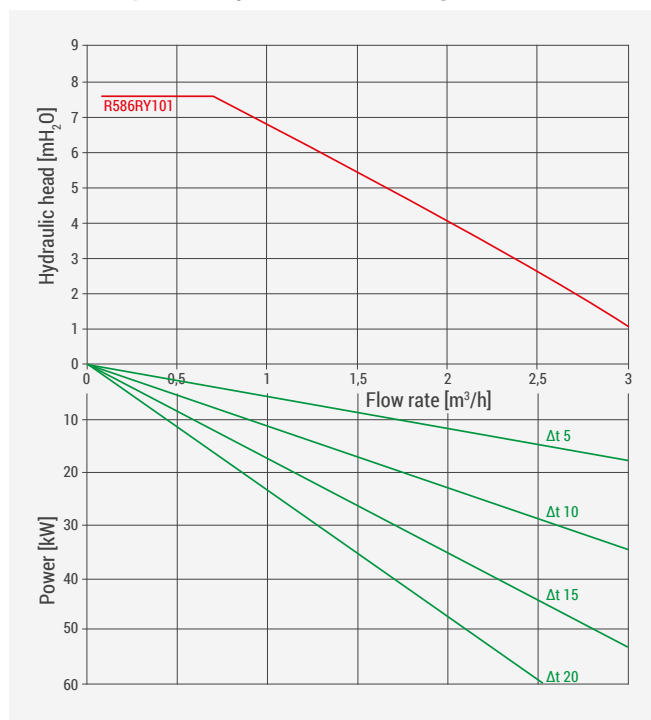

NOTE. For proper interpretation of the diagram, see example on page 15.

NOTE. Curves obtained with circulator set to "constant speed, level III" mode.



R586RY102 - R586RY112



Operation

R586RY102 and R586RY112 distribution units with R296 mixing ball valve can be used in heating and cooling systems to control the system delivery temperature.

Operation is possible only when combined to an actuator and possibly a KLIMAbus thermoregulation system.

The units include an interception valve with thermometer on both delivery and return circuits and a check valve on the return spacer.

The two delivery and return outputs are reversible and a R284Y021 differential by-pass kit can be installed in between (see paragraph "Main characteristics").

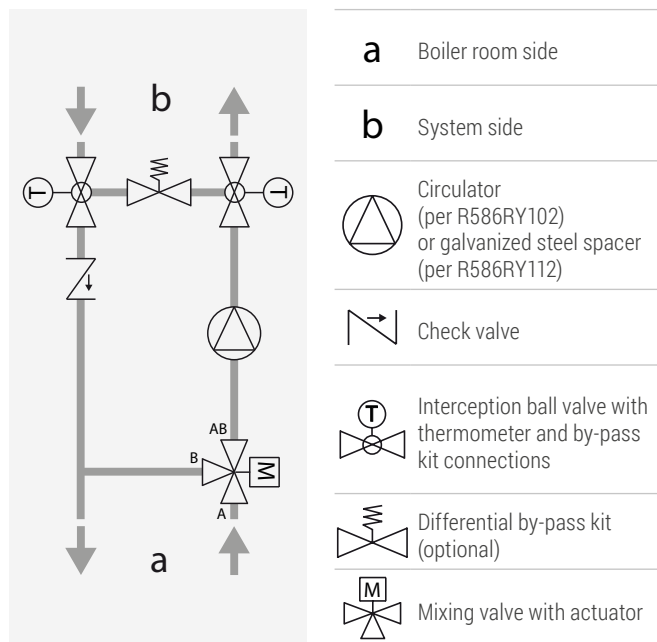

NOTE. For proper interpretation of the diagram, see example on page 15.

NOTE. Curves obtained with circulator set to "constant speed, level III" mode.

Specific technical data

- Temperature range: 5÷100 °C
- Max. working pressure: 10 bar
- Connections: system side: 1" F ISO 228
boiler side: 1 1/2" M ISO 228
outputs centre distance: 125 mm
- Weight: 6,8 kg (with circulator); 5,0 kg (without circulator)

Materials

- Interception ball valves: CW617N brass body, PTFE sealings, plastic handle
- Mixing valve: brass body, plastic handle, hard drawn copper pipe connecting delivery and return circuits, EPDM gaskets
- Spacer with check valve: CW617N brass body, POM check valve
- Polypropylene foam insulation (EPP)
- Gaskets: EPDM

Flow rate/power/hydraulic head diagram

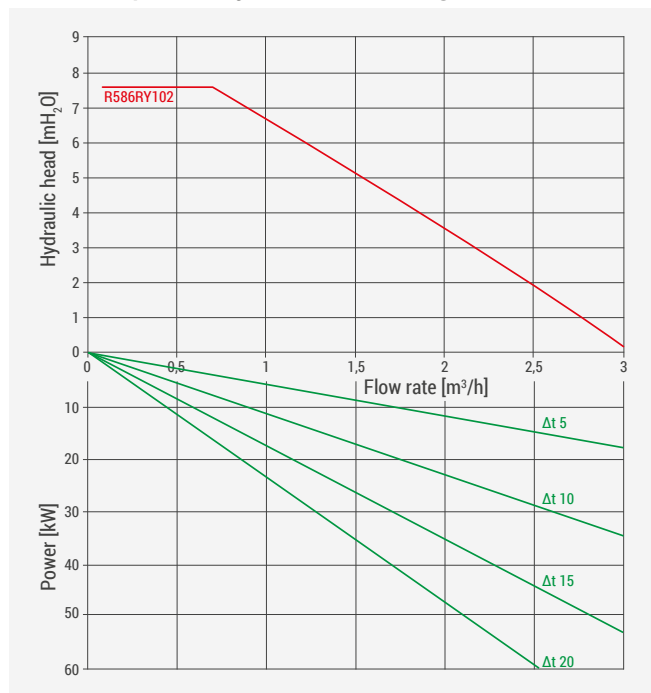

Kv R296 mixing valve

Manual handle position	0 (B→AB)	1	2	3	4	5 (A→AB)
Kv (AB)	2,0	4,8	7,8	9,8	14,1	18,9

▶ Actuator installation

K275Y002 or K275Y011/013 actuators can be installed on R296 mixing valves.

Before closing the R586R unit with the front insulation shell, with a sharp-edge cutter carve out the shape of the K275 actuator (to make this operation easier, the shape of the actuator is reproduced on the back of the front insulation shell).



Actuator installation K275Y011/013 on R296 mixing valve

Use the Connection kit 0296 included in the actuator package.

Before installing the K275Y011/013 actuator on the R296 mixing valve, make sure the valve is in by-pass position (milling in OFF position) and the actuator is in closing position. For the K275Y013 actuator:

With the body valve on the left and the by-pass T-shaped fitting on the right, the DIP1 must be positioned on OFF (1a).

With the body valve on the right and the by-pass T-shaped fitting on the left, the DIP1 must be positioned on ON (1b).

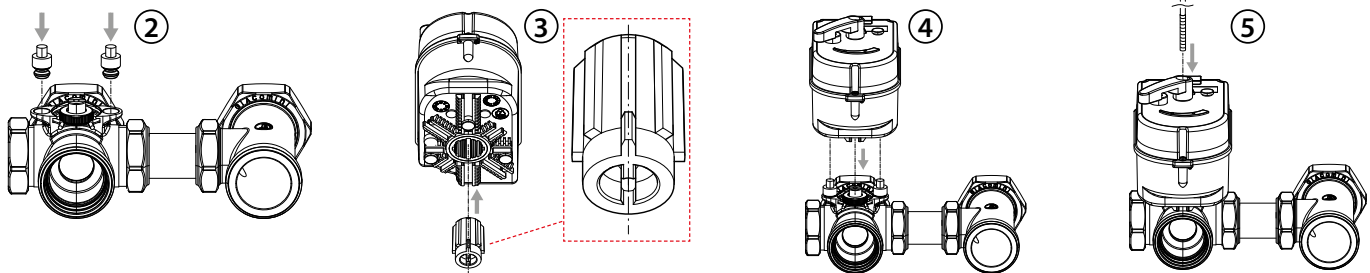
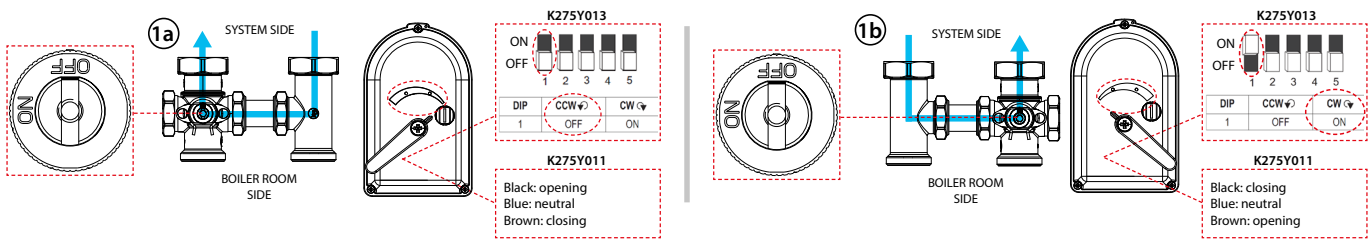
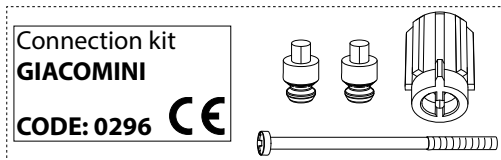

Actuator installation K275Y002 on R296 mixing valve

Use the Connection kit 0296 included in the actuator package.

Before installing the K275Y002 actuator on the R296 mixing valve, make sure the valve is in by-pass position (milling in OFF position) and the actuator is in closing position.

With the valve body on the left and the by-pass T-shaped fitting on the right, the DIP1 must be positioned on OFF (1a).

With the valve body on the right and the by-pass T-shaped fitting on the left, the DIP1 must be positioned on ON (1b).

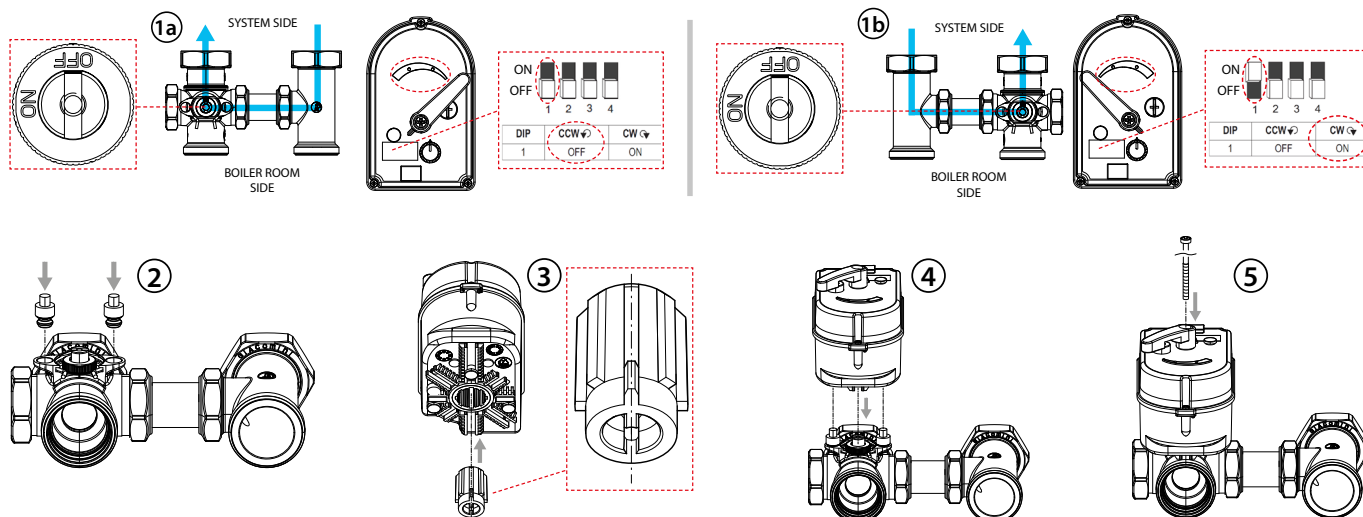
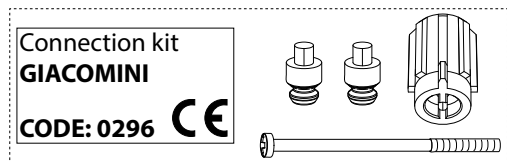

NOTE. When the DIP1 position is changed, actuator calibration begins. The LED blinks (1x/sec) and the actuator is turned right and left. When this happens, leave the actuator in the AUTO position, do not change the settings and do not cut off electric power.

When calibrating the actuator, to protect the system, the circulator must be turned off to prevent temperature fluctuations in the system.

Installation of temperature probes

The temperature probe must be installed after the system circulator, at a max. distance of 1,5 m from the actuator.

- For contact installation, use the kit included with the actuator. This requires a flat surface with a min. length of 40 mm to position the probe.
- For immersion installation, the probe must be installed in a housing up to half of the piping diameter (the R227Y003 housing can be used by installing it in the ball valve sockets included with the R586R unit). This requires a suitable mechanic protection of the probe and probe wire. The wire must be insulated in case of contact with very hot parts.



R586RY103 - R586RY113

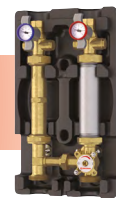

➤ Operation

R586RY103 and R586RY113 distribution units with R297 mixing sector valve can be used in heating and cooling systems to control the system delivery temperature.

Operation is possible only when combined to an actuator and possibly a KLIMAbus thermoregulation system.

The units include an interception valve with thermometer on both delivery and return circuits and a check valve on the return spacer.

The mixing valve is also equipped with a manually adjustable by-pass to insert the function of fixed recirculation of the system.

The two delivery and return outputs are NOT reversible (see "Main Characteristics" paragraph) and a R284Y021 differential by-pass kit can be installed in between (see paragraph "Main characteristics").

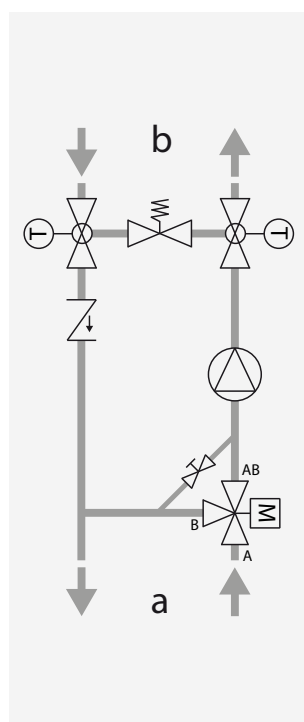

- a** Boiler room side
- b** System side
- Circulator (per R586RY103) or galvanized steel spacer (per R586RY113)
- Check valve
- Interception ball valve with thermometer and by-pass kit connections
- Differential by-pass kit (optional)
- Mixing valve with actuator
- Mixing valve recirculation by-pass

➤ Specific technical data

- Temperature range: 5÷100 °C
- Max. working pressure: 10 bar
- Connections: system side: 1" F ISO 228
boiler side: 1 1/2" M ISO 228
outputs centre distance: 125 mm
- Weight: 6,7 kg (with circulator); 4,9 kg (without circulator)

Materials

- Interception ball valves: CW617N brass body, PTFE sealings, plastic handle
- Valvola miscelatrice: corpo in ottone, tubo di raccordo in ottone, Gaskets in EPDM, FPM e PTFE.
- Spacer with check valve: CW617N brass body, POM check valve
- Polypropylene foam insulation (EPP)
- Gaskets: EPDM

Flow rate/power/hydraulic head diagram

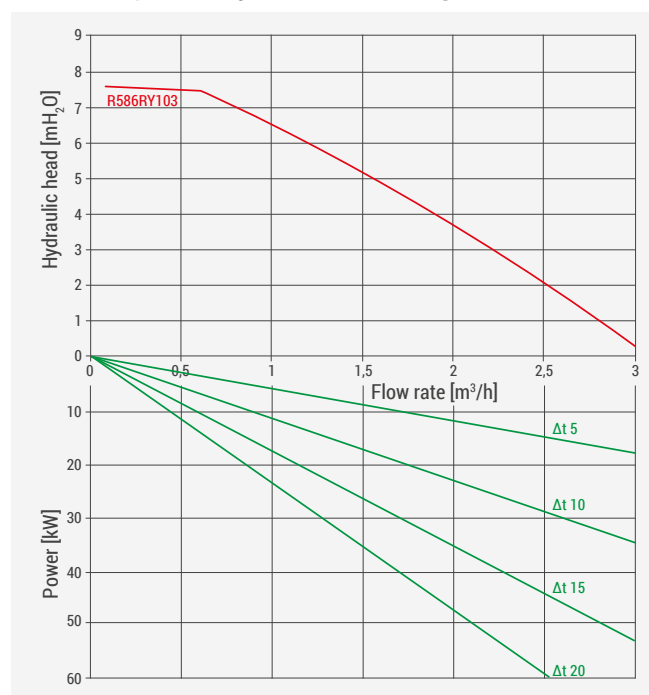

NOTE. For proper interpretation of the diagram, see example on page 15.

NOTE. Curves obtained with circulator set to "constant speed, level III" mode.

R297 mixing valve Kv

Equal percentage valve: to absolute value variations of the stroke always corresponds the same % variation of the outflow coefficient (example: if the valve opens by 10 %, the Kv will vary by 10 %), notwithstanding the position of the recirculation by-pass.

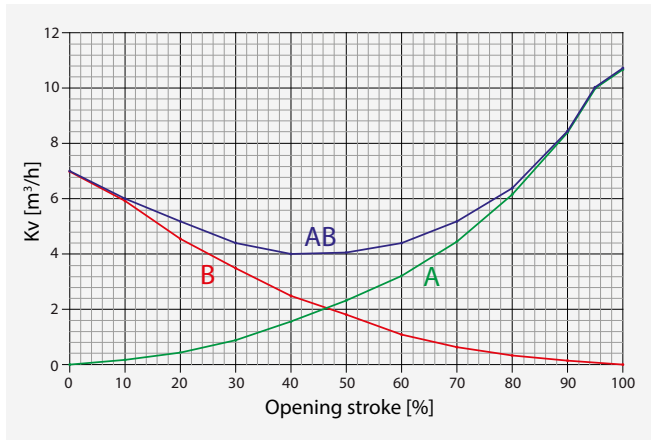

Operation of mixing valve recirculation by-pass

R297 mixing valves include a by-pass which activates a fix recirculation on the mixing valve (B→AB).

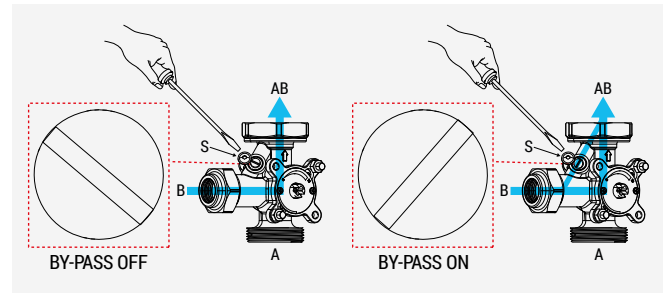

⚠ WARNING. Do not loosen the safety device (S) next to the by-pass adjustment screw. High pressures may violently eject it from its seat.

▶ Actuator installation

K275Y002 or K275Y013 actuators can be installed on R297 mixing valves.

Before closing the R586R unit with the front insulation shell, with a sharp-edge cutter carve out the shape of the K275 actuator (to make this operation easier, the shape of the actuator is reproduced on the back of the front insulation shell).



Actuator installation K275Y011/013 on R297 mixing valve

Use the Connection kit 0297 included in the actuator package.

Before installing the K275Y011/013 actuator on the R297 mixing valve, make sure the valve is in by-pass position ("A" notch downwards), the actuator is in closing position, put the indicator in position for a clockwise rotation and the DIP1 is in ON position for K275Y013.

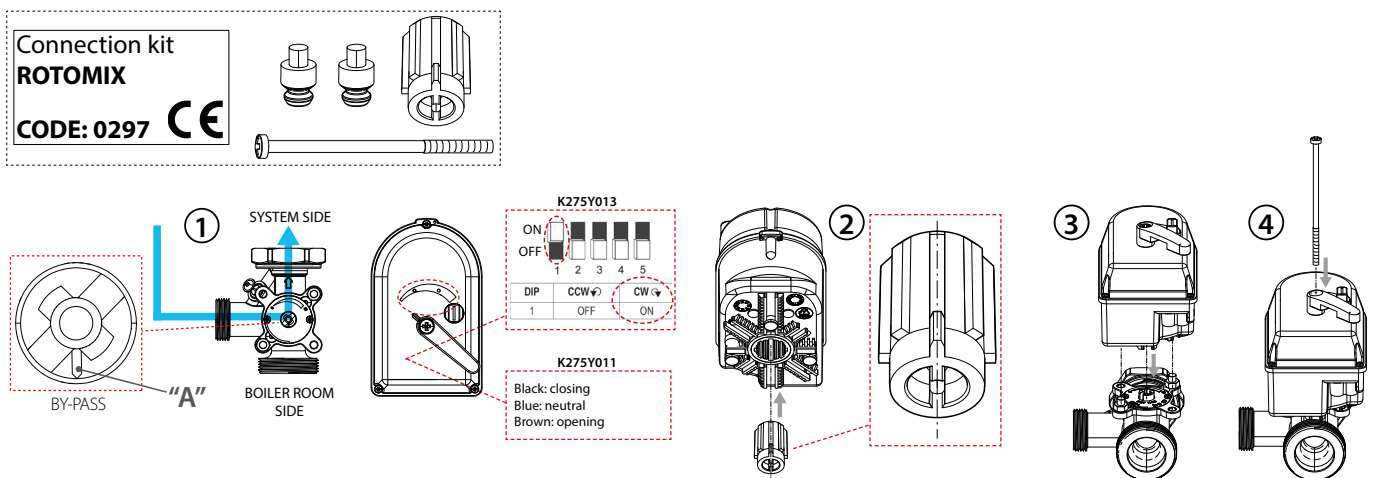

Actuator installation K275Y002 on R297 mixing valve

Use the Connection kit 0297 included in the R586R package.

Before installing the K275Y002 actuator on the R297 mixing valve, make sure the valve is in by-pass position ("A" notch downwards), the actuator is in closing position and the DIP 1 is in ON position.

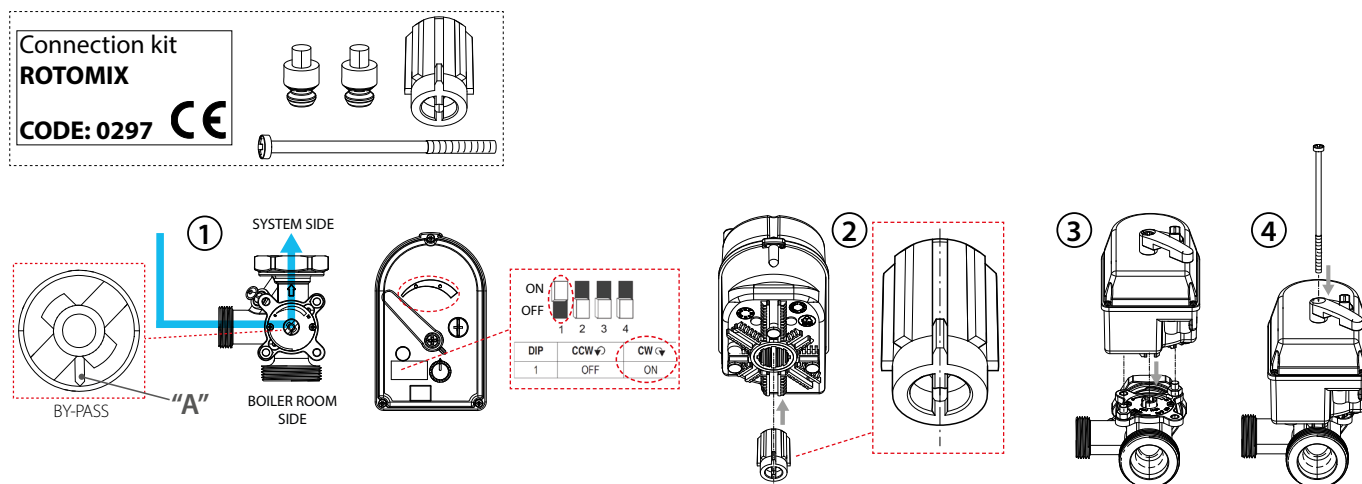

NOTE. When the DIP1 position is changed, actuator calibration begins. The LED blinks (1x/sec) and the actuator is turned right and left. When this happens, leave the actuator in the AUTO position, do not change the settings and do not cut off electric power. When calibrating the actuator, to protect the system, the circulator must be turned off to prevent temperature fluctuations in the system.

Installation of temperature probes

The temperature probe must be installed after the system circulator at a max. distance of 1,5 m from the actuator.

- For contact installation use the kit included with the actuator. This requires a flat surface with a min. length of 40 mm to position the probe.
- For immersion installation, the probe must be installed in a housing up to half of the piping diameter (the R227Y003 housing can be used by installing it in the ball valve sockets included with the R586R unit). This requires a suitable mechanic protection of the probe and probe wire. The wire must be insulated in case of contact with very hot parts.

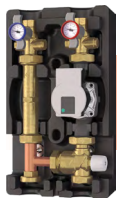

R586RY104 - R586RY114

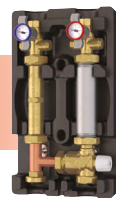

➤ Operation

R586RY104 and R586RY114 distribution units with mixing thermostatic valve can be used in heating-only systems to control the system delivery temperature and maintain it at the desired constant temperature.

The setting range of the mixing thermostatic valve allows for applications on low-temperature radiant systems and/or fan-coil applications.

The units include interception valves with thermometer on both delivery and return circuits and a check valve on the return spacer.

The two delivery and return outputs are reversible and the R284Y021 differential by-pass kit can be installed in between (see paragraph "Main characteristics").

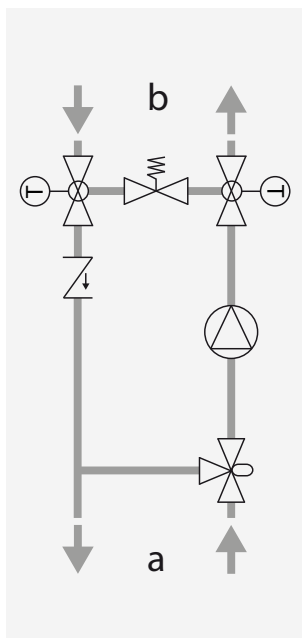

- a** Boiler room side
- b** System side
- Circulator (per R586RY104) or galvanized steel spacer (per R586RY114)
- Check valve
- Interception ball valve with thermometer and by-pass kit connections
- Differential by-pass kit (optional)
- Thermostatic mixing valve

➤ Specific technical data

- Temperature range: 5÷95 °C
- Max. working pressure: 5 bar
- Connections: system side: 1" F ISO 228
boiler side: 1 1/2" M ISO 228
outputs centre distance: 125 mm
- Weight: 7,0 kg (with circulator); 5,2 kg (without circulator)

Materials

- Interception ball valves: CW617N brass body, PTFE sealings, plastic handle
- Valvola miscelatrice: corpo in ottone, otturatore in PSU GF20, molla in acciaio inox, Gaskets in EPDM, sensore a cera.
- Spacer with check valve: CW617N brass body, POM check valve
- Polypropylene foam insulation (EPP)
- Gaskets: EPDM

Flow rate/power/hydraulic head diagram

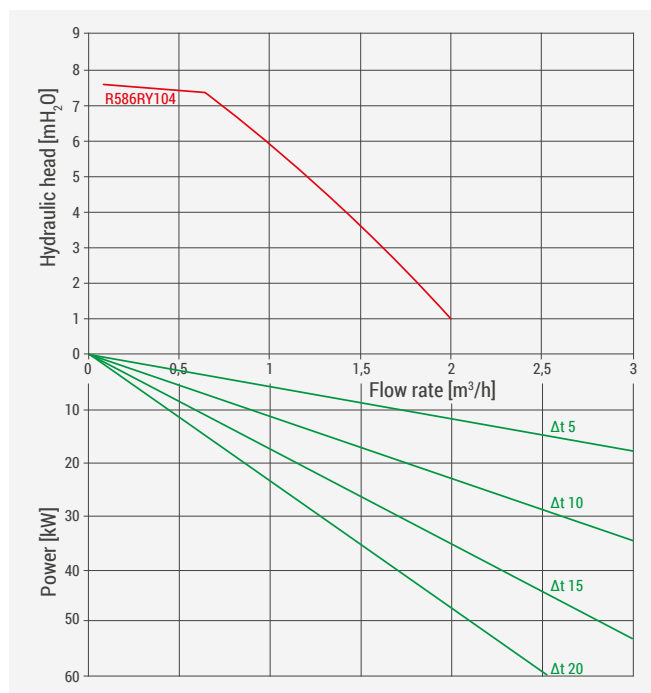

NOTE. For proper interpretation of the diagram, see example on page 15.

NOTE. Curves obtained with circulator set to "constant speed, level III" mode.

Thermostatic mixing valve

Before closing the R586R unit with the front insulation shell, with a sharp-edge cutter carve the side to adjust the position of the mixing thermostatic valve handwheel (to make this operation easier, the shape of the handwheel is reproduced on the side of the front insulation shell).

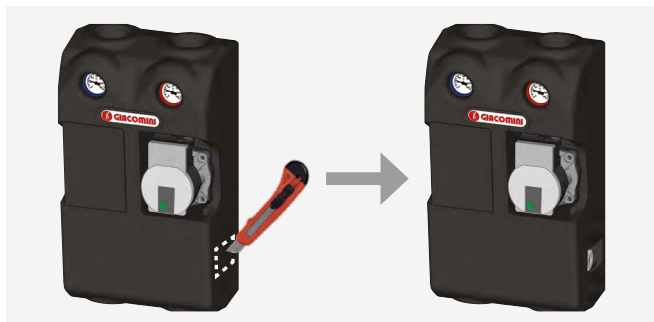

- Kv: 3,6
- Sensitivity: ± 2 °C

Handwheel position	Min.	1	2	3	4	5	Max.
Temperature [°C]	29	30	40	47	54	60	64

➤ Dimensions

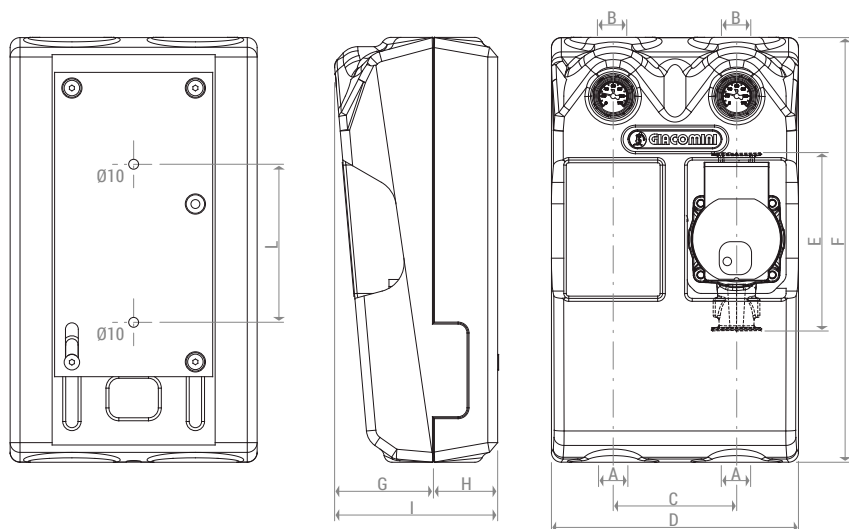

PRODUCT CODE	A x B	C [mm]	D [mm]	E [mm]	F [mm]	G [mm]	H [mm]	I [mm]	L [mm]
R586RY101									
R586RY102									
R586RY103									
R586RY104	1 1/2" M x 1" F	125	250	180	430	100	65	165	160
R586RY111									
R586RY112									
R586RY113									
R586RY114									

➤ Example of application diagram

Application diagram for heating-only system with R586SEP complete of R586RY101 for high-temperature radiator zone + R586RY102/103 for low-temperature radiant system zone and mixing valve actuator controlled by KLIMAbus thermoregulation.

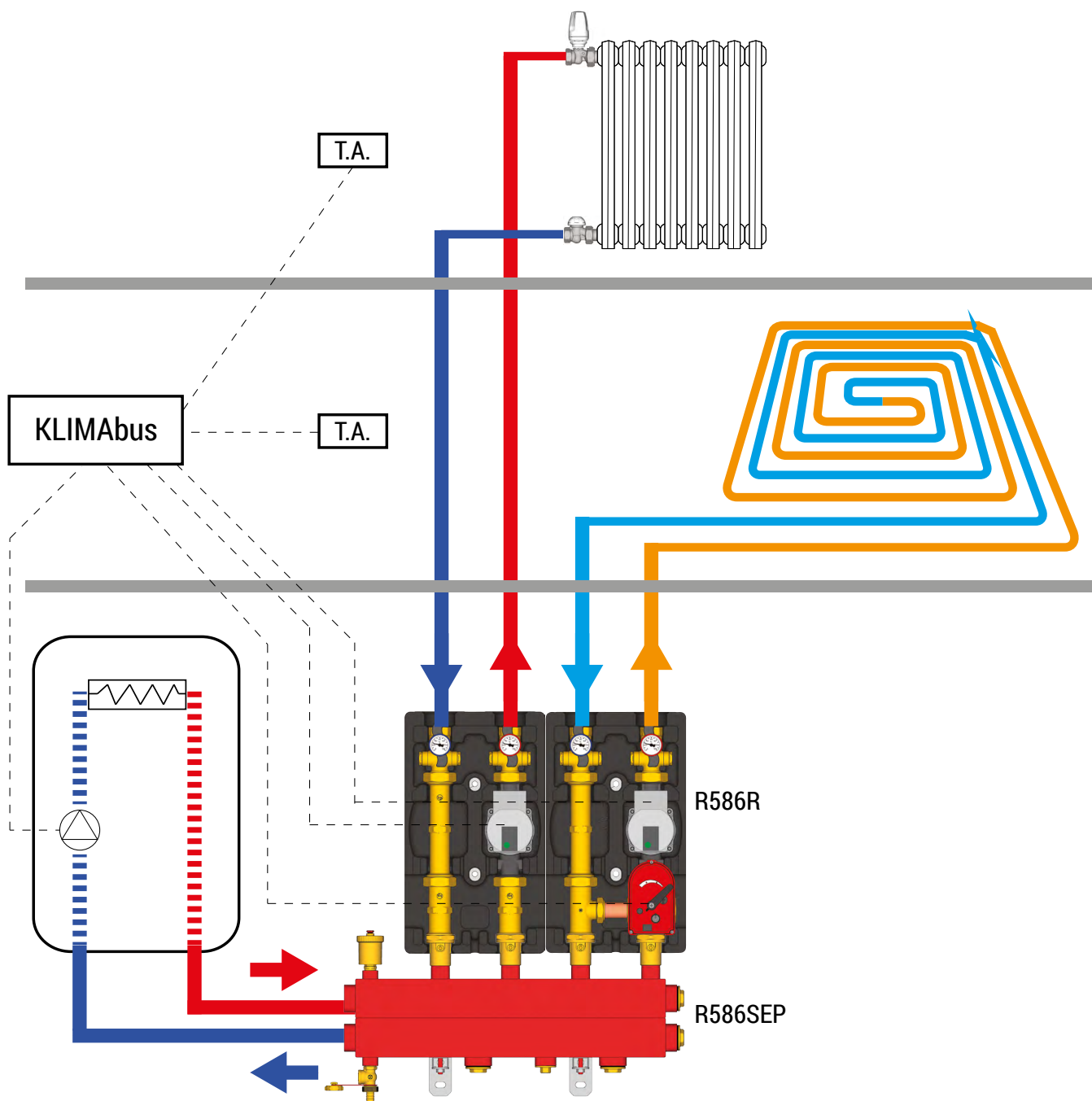

➤ Interpretation of flow rate/power/hydraulic head diagram

With the system Power and Δt project data known, trace a horizontal line starting from the Power axis up to intersecting the required Δt (A).

From the obtained intersection point, trace a vertical line up to intercepting the operational curve of the R586R unit (B), this will show the operational flow rate and hydraulic head available downstream the R586R unit (B, C).

Example:

Power = 20 kW

$\Delta t = 10\text{ }^{\circ}\text{C}$

The indications given above will result in a flow rate equal to 1,75 m³/h with a useful hydraulic head at the circulator of 4,8 mH₂O.

NOTE. Curves obtained with circulator set to "constant speed, level III" mode.

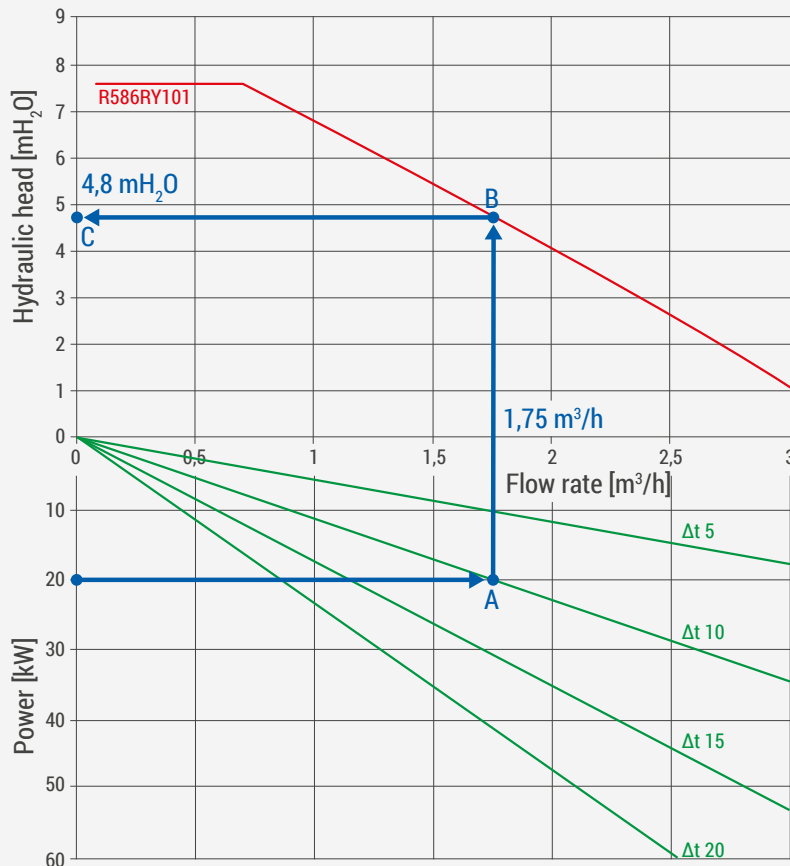

Power	Power required by the heating/cooling system zone downstream of the R586R distribution unit
Δt	Temperature difference between delivery and return of the heating/cooling system zone downstream of the R586R distribution unit (Δt depends on the type of system)
Flow rate	Operational flow rate downstream of the R586R distribution unit
Hydraulic head	Hydraulic head available downstream of the R586R distribution unit
R586R unit curve	Operational curve of the R586R distribution unit (Wilo Yonos Para circulator + all various components)

➤ Standards reference

- PED 2014/68/EU, article 4.3
- LVD 2014/35/EU
- EMC 2014/30/EU
- RoHS 2011/65/EU
- ErP 2009/125/CE
- ErP 2015

➤ Product specifications

R586RY101

Distribution unit to control heating and cooling of one system zone. Connections: system side 1" F ISO 228; boiler side 1 1/2" M ISO 228; delivery and return outputs centre distance 125 mm. Includes: brass delivery output equipped with low-energy consumption circulator complying with directive ErP 2009/125/CE (centre distance 180 mm) and interception ball valve with integrated thermometer (0÷120 °C scale); brass return output equipped with interception ball valve with integrated thermometer (0÷120 °C scale) and POM check valve. Reversible delivery and return outputs. EPP rigid insulation (density 35 kg/m³). Wall-mount plate (screw anchors not included). EPDM gaskets. Temperature range 5÷100 °C. Max. working pressure 10 bar. Weight 5,8 kg. Optional installation of differential by-pass kit between the two delivery and return outputs. Optional installation of interception ball valve upstream of distribution unit.

R586RY111

Distribution unit to control heating and cooling of one system zone. Connections: system side 1" F ISO 228; boiler side 1 1/2" M ISO 228; delivery and return outputs centre distance 125 mm. Includes: brass delivery output equipped with spacer to install circulator (centre distance 180 mm) and interception ball valve with integrated thermometer (0÷120 °C scale); brass return output equipped with interception ball valve with integrated thermometer (0÷120 °C scale) and POM check valve. Reversible delivery and return outputs. EPP rigid insulation (density 35 kg/m³). Wall-mount plate (screw anchors not included). EPDM gaskets. Temperature range 5÷100 °C. max. working pressure 10 bar. Weight 4,0 kg. Optional installation of differential by-pass kit between the two delivery and return outputs. Optional installation of interception ball valve upstream of distribution unit.

R586RY102

Distribution unit to control heating and cooling of one system zone. Connections: system side 1" F ISO 228; boiler side 1 1/2" M ISO 228; delivery and return outputs centre distance 125 mm. Includes: brass delivery output equipped with low-energy consumption circulator complying with directive ErP 2009/125/CE (centre distance 180 mm), interception ball valve with integrated thermometer (0÷120 °C scale) and motorizable mixing ball valve; brass return output equipped with interception ball valve with integrated thermometer (0÷120 °C scale) and POM check valve. Reversible delivery and return outputs. EPP rigid insulation (density 35 kg/m³). Wall-mount plate (screw anchors not included). EPDM gaskets. Temperature range 5÷100 °C. Max. working pressure 10 bar. Weight 6,8 kg. Optional installation of differential by-pass kit between the two delivery and return outputs. Optional installation of interception ball valve upstream of distribution unit. Optional installation of the mixing valve actuator controllable by KLIMAbus thermoregulation items.

R586RY112

Distribution unit to control heating and cooling of one system zone. Connections: system side 1" F ISO 228; boiler side 1 1/2" M ISO 228; delivery and return outputs centre distance 125 mm. Includes: brass delivery output equipped with spacer to install circulator (centre distance 180 mm), interception ball valve with integrated thermometer (0÷120 °C scale) and motorizable mixing ball valve; brass return output equipped with interception ball valve with integrated thermometer (0÷120 °C scale) and POM check valve. Reversible delivery and return outputs. EPP rigid insulation (density 35 kg/m³). Wall-mount plate (screw anchors not included). EPDM gaskets. Temperature range 5÷100 °C. Max. working pressure 10 bar. Weight 5,0 kg. Optional installation of differential by-pass kit between the two delivery and return outputs. Optional installation of interception ball valve upstream of distribution unit. Optional installation of the mixing valve actuator controllable by KLIMAbus thermoregulation items.

R586RY103

Distribution unit to control heating and cooling of one system zone. Connections: system side 1" F ISO 228; boiler side 1 1/2" M ISO 228; delivery and return outputs centre distance 125 mm. Includes: brass delivery output equipped with low-energy consumption circulator complying with directive ErP 2009/125/CE (centre distance 180 mm), interception ball valve with integrated thermometer (0÷120 °C scale) and motorizable sector mixing valve equipped with optional fix by-pass; brass return output equipped with interception ball valve with integrated thermometer (0÷120 °C scale) and POM check valve. Reversible delivery and return outputs. EPP rigid insulation (density 35 kg/m³). Wall-mount plate (screw anchors not included). EPDM gaskets. Temperature range 5÷100 °C. Max. working pressure 10 bar. Weight 6,7 kg. Optional installation of differential by-pass kit between the two delivery and return outputs. Optional installation of interception ball valve upstream of distribution unit. Optional installation of mixing valve actuator controllable by KLIMAbus thermoregulation items.

R586RY113

Distribution unit to control heating and cooling of one system zone. Connections: system side 1" F ISO 228; boiler side 1 1/2" M ISO 228; delivery and return outputs centre distance 125 mm. Includes: brass delivery output equipped with spacer to install circulator (centre distance 180 mm), interception ball valve with integrated thermometer (0÷120 °C scale) and motorizable sector mixing valve equipped with optional fix by-pass; brass return output equipped with interception ball valve with integrated thermometer (0÷120 °C scale) and POM check valve. Reversible delivery and return outputs. EPP rigid insulation (density 35 kg/m³). Wall-mount plate (screw anchors not included). EPDM gaskets. Temperature range 5÷100 °C. Max. working pressure 10 bar. Weight 4,9 kg. Optional installation of differential by-pass kit between the two delivery and return outputs. Optional installation of interception ball valve upstream of distribution unit. Optional installation of mixing valve actuator controllable by KLIMAbus thermoregulation items.

R586RY104

Distribution unit to control heating and cooling of one system zone. Connections: system side 1" F ISO 228; boiler side 1 1/2" M ISO 228; delivery and return outputs centre distance 125 mm. Includes: brass delivery output equipped with low-energy consumption circulator complying with directive ErP 2009/125/CE (centre distance 180 mm), interception ball valve with integrated thermometer (0÷120 °C scale) and thermostatic mixing valve; brass return output equipped with interception ball valve with integrated thermometer (0÷120 °C scale) and POM check valve. Reversible delivery and return outputs. EPP rigid insulation (density 35 kg/m³). Wall-mount plate (screw anchors not included). EPDM gaskets. Temperature range 5÷95 °C. Max. working pressure 5 bar. Weight 7,0 kg. Optional installation of differential by-pass kit between the two delivery and return outputs. Optional installation of interception ball valve upstream of distribution unit.

R586RY114

Distribution unit to control heating and cooling of one system zone. Connections: system side 1" F ISO 228; boiler side 1 1/2" M ISO 228; delivery and return outputs centre distance 125 mm. Includes: brass delivery output equipped with spacer for to install circulator (centre distance 180 mm), interception ball valve with integrated thermometer (0÷120 °C scale) and thermostatic mixing valve; brass return output equipped with interception ball valve with integrated thermometer (0÷120 °C scale) and POM check valve. Reversible delivery and return outputs. EPP rigid insulation (density 35 kg/m³). Wall-mount plate (screw anchors not included). EPDM gaskets. Temperature range 5÷95 °C. Max. working pressure 5 bar. Weight 5,2 kg. Optional installation of differential by-pass kit between the two delivery and return outputs. Optional installation of interception ball valve upstream of distribution unit.

⚠ Safety Warning. Installation, commissioning and periodical maintenance of the product must be carried out by qualified operators in compliance with national regulations and/or local standards. A qualified installer must take all required measures, including use of Individual Protection Devices, for his and others' safety. An improper installation may damage people, animals or objects towards which Giacomini S.p.A. may not be held liable.

♻ Package Disposal. Carton boxes: paper recycling. Plastic bags and bubble wrap: plastic recycling.

ℹ Additional information. For more information, go to giacomini.com or contact our technical assistance service. This document provides only general indications. Giacomini S.p.A. may change at any time, without notice and for technical or commercial reasons, the items included herewith. The information included in this technical sheet do not exempt the user from strictly complying with the rules and good practice standards in force.

♻ Product Disposal. Do not dispose of product as municipal waste at the end of its life cycle. Dispose of product at a special recycling platform managed by local authorities or at retailers providing this type of service.